

ART. 403-AP Contatto magnetico in metallo di ridotte dimensioni, colore alluminio / Compact metal magnetic contact, silver color

ART. 403-AP-M Contatto magnetico in metallo di ridotte dimensioni, colore marrone / Compact metal magnetic contact, brown color

SPECIFICHE GENERALI
GENERAL SPECIFICATIONS

Materiale contenitore Housing material	Lega metallica Metal alloy
Funzionamento Operation	NC con i due componenti vicini NC when the two components are near
Temp. di funzionamento Operating temperature	-25°C ÷ +50°C
Grado di protezione IP degree	Certificato IPx2 (dichiarato IP65 da Cooper CSA) Certified IPx2 (declared IP65 by Cooper CSA)
V max	42,4 Vpeak - 60Vdc
I max	1 A
W max	10 W
Identificazione Identification	Numero seriale/lotto su ogni componente Serial number/batch on each component

I contatti magnetici sono componenti passivi, le grandezze elettriche indicate sono le massime applicabili
Magnetic contacts are passive components, max applicable voltage and current are displayed in table

EN50131-2-6

GR 2

CL III



INSTALLAZIONE CONFORME ALLA NORMA
INSTALLATION AS PER STANDARD

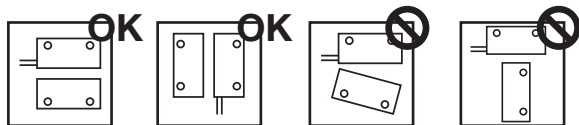
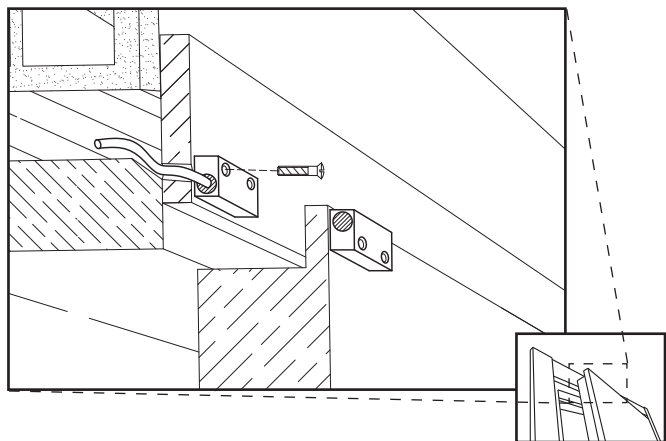

La certificazione decade per installazioni diverse da quelle rappresentate nelle figure.
Certification is void if the devices are installed differently.

DISTANZE OPERATIVE / OPERATIONAL APPROACH AND REMOVAL DISTANCES

Su superfici non ferromagnetiche installare i due corpi a distanza Y inferiore a 18mm (distanza raccomandata 7mm), su superfici ferromagnetiche a distanza Y inferiore a 6mm (distanza raccomandata 3mm). Le distanze operative riportate in tabella per gli assi X e Z sono state calcolate con i corpi installati alla distanza raccomandata.

Install the two components at Y distance less than 18mm (recommended 7mm) on non-ferromagnetic surfaces, at Y distance less than 6mm (recommended 3mm) on ferromagnetic surfaces. The operating distances displayed in table for axes X and Z have been calculated with the components mounted at the recommended distance.

Asse / Axis	Z+		Z-		X+ / X-		Y	
Azione Action								
Contatto Contact								
Superfici non ferromagnetiche Non-ferromagnetic surfaces	20 mm	34 mm	20 mm	34 mm	7 mm	20 mm	17 mm	26 mm
Superfici ferromagnetiche Ferromagnetic surfaces	4 mm	8 mm	9 mm	15 mm	5 mm	14 mm	5 mm	12 mm
Tolleranze / Tolerance	-0% +50%*	+0% -40%**	-0% +50%	+0% -40%	-0% +170%	+0% -60%	-0% +50%*	+0% -30%**

* = -0% +100% su superfici ferromagnetiche / on ferromagnetic surfaces

** = +0% -50% su superfici ferromagnetiche / on ferromagnetic surfaces

INDICAZIONI DI FISSAGGIO / FIXING INSTRUCTIONS

Fissare i componenti tenendo conto delle distanze operative riportate in tabella. Utilizzare viti autofilettanti \varnothing 2,9. Installare i due componenti rispettando l'allineamento dei fori indicato nella figura a lato.

Fix the elements paying attention to the operational approach and removal distance. Use \varnothing 2.9 tapping screws. Install the components according to the alignment of the holes depicted in the picture aside.

COLLEGAMENTO / WIRING

